

CENTURY®

LEGENDARY LEADERSHIP



OWNER'S MANUAL

20 SERIES 4 CAR CARRIERS

INSTALLATION, OPERATION, MAINTENANCE & PARTS

**NOTE: MANUAL including SPECIFICATIONS, subject to change without notice
All ratings specified are based on structural factors only,
not vehicle capacities or capabilities.**

CENTURY®

Miller Industries Towing Equipment Inc.
8503 Hilltop Drive
Ooltewah, Tennessee 37363

FORM NO. 0500804
REV. 1/16
PRICE \$25.00

Section V - PARTS

This Section is provided by the manufacturer for the purpose of ordering any component part of the **Series 20 Carrier** that may be required when part replacement is necessary. Be certain to use only original equipment replacement parts for warranty purposes as well as for keeping your **Series 20 Carrier** in its original state and optimum operating capacities.

When ordering replacement or spare parts be sure to provide the following information to your carrier manufacturer authorized representative.

1. **Manual Number & Date of Publication**
2. **Manual Page Number**
3. **Page Title**
4. **Reference Number of Part Desired**
5. **Part Number**
6. **Part Description**
7. **Quantity of Part Desired**

Providing this information will help ensure that the correct parts will be delivered to you in an expedient manner without delay. Should additional information be required for repair or replacement of certain components, contact **MILLER Ind., Hermitage, PA, Phone: 724-981-3328, FAX 724-981-0277.**

The Manufacturer reserves the right, without notice or obligation, to improve or modify their products, which may change the specifications, models and feature availability.

Section V - PARTS

TILT CYLINDER COMPONENTS WITH OUTBOARD SADDLES

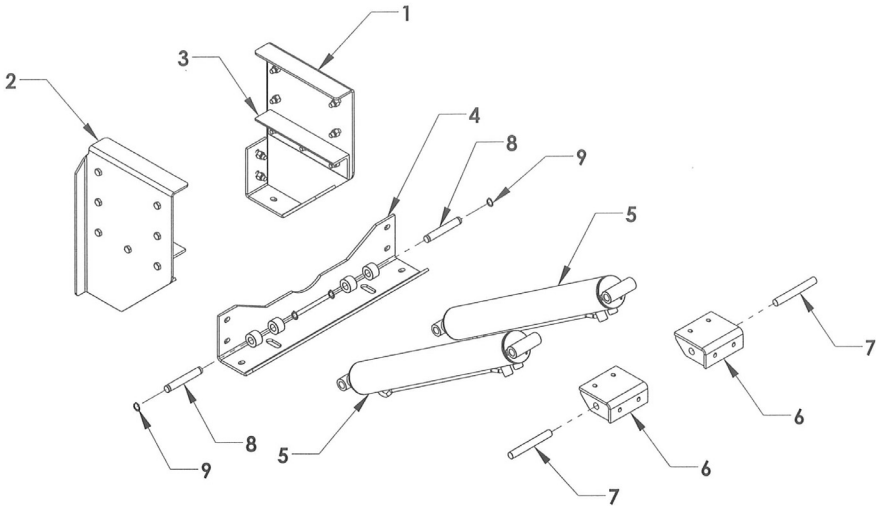

REF	PART #	DESCRIPTION	QPU
1	1A510R	TILT CYLINDER SADDLE (LONG) - RIGHT	1
	1A540R	TILT CYLINDER SADDLE (SHORT) - RIGHT	1
2	1A510L	TILT CYLINDER SADDLE (LONG) - LEFT	1
	1A540L	TILT CYLINDER SADDLE (SHORT) - LEFT	1
3	1A514	UNDERFRAME SUPPORT ANGLE	2
4	1A520	CONNECTING ANGLE	2
5	72114E	TILT CYLINDER (LONG)	1
	72114	TILT CYLINDER (SHORT)	2
6	13420	TILT CYLINDER FOOT	2
7	13423	TILT CYLINDER BASE PIN .980 x 7.500	2
8	1A724	TILT CYLINDER ROD PIN .980 x 6.375	2
9	86100E	SNAP RING, 1.000 EXTERNAL	4

Section V - PARTS

**TILT CYLINDER COMPONENTS
WITH INBOARD SADDLES**

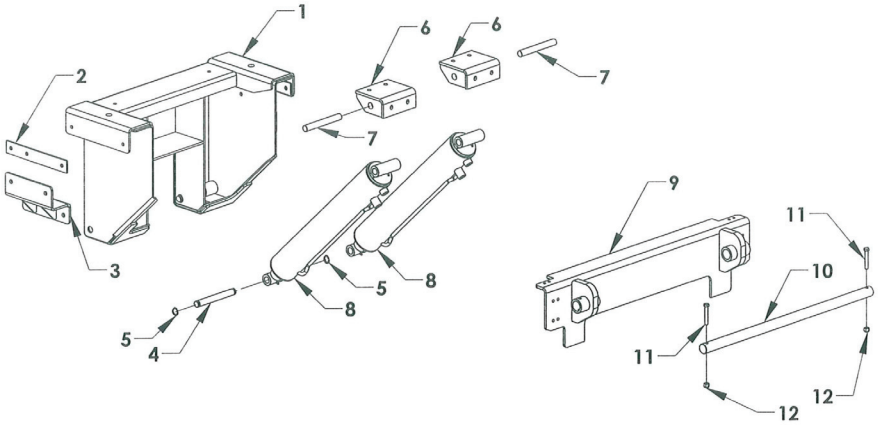

REF	PART #	DESCRIPTION	QPU
1	1A900	INTERNAL SADDLE	1
2	1A821S	SADDLE SHIM	2
3	1A925	FRAME MOUNTING BRACKET	2
4	1A828	TILT CYLINDER PIN .980 x 8.125	2
5	86100E	RETAINING RING 1.00 EXTERNAL	4
6	13420	TILT CYLINDER FOOT	2
7	13423	TILT CYLINDER PIN .980 x 7.50	2
8	72114	TILT CYLINDER	2
9	17500	HINGE ANGLE	1
10	17198	HINGE PIN 1.50 x 36	1
11	81451	BOLT 1/2-20 UNF x 3 GRADE 5	2
12	83324	NYLON LOCK NUT 1/2-20 UNF	2

Section V - PARTS

BODY LOCK

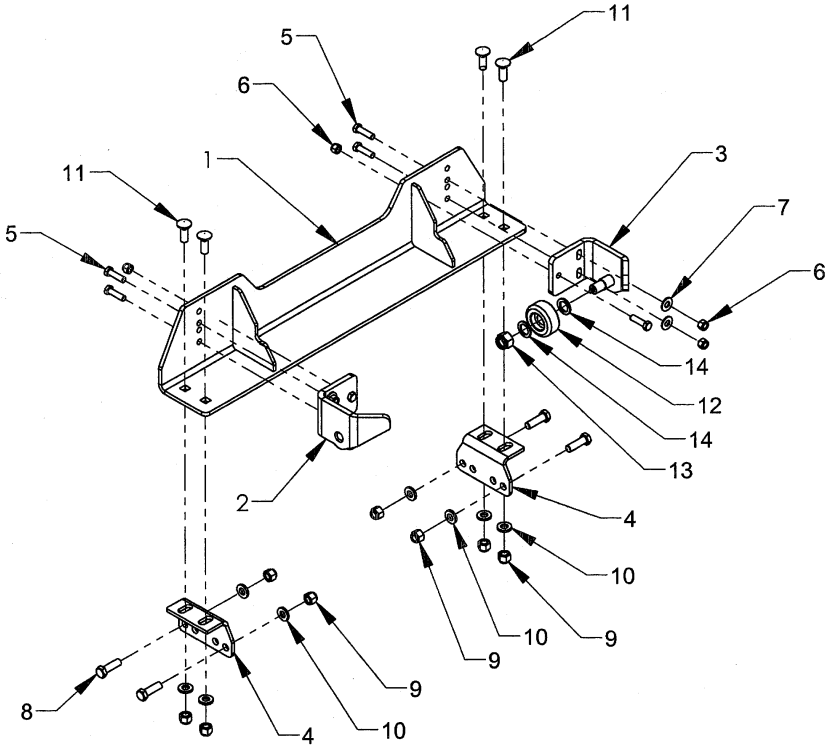

REF	PART #	DESCRIPTION	QPU
1	364002	BODY LOCK WELDMENT	1
2	36315L	BODY LOCK HOLD-DOWN (LEFT)	1
3	36315R	BODY LOCK HOLD-DOWN (RIGHT)	1
4	364062	MOUNTING BRACKET	2
5	81438	BOLT, HHCS 1/2-20 x 1-3/4	6
6	83324	NYLON LOCK NUT, 1/2-20 ZP	6
7	82310	FLAT WASHER, 1/2 ZP	4
8	81520	BOLT, HHCS 5/8-11 x 2 ZP GRADE 5	4
9	83411	NYLON LOCK NUT, 5/8-11 ZP	4
10	82410	FLAT WASHER, 5/8 ZP	8
11	81517	CARRIAGE BOLT, 5/8-11 x 1-3/4 ZP GRADE 5	4
12	36310	HOLD-DOWN WHEEL	2
13	83610	NYLON LOCK NUT, 7/8-14 ZP	2
14	82710	FLAT WASHER 1 ID x 1-1/2 OD	4

Section V - PARTS

DIRECT MOUNT PUMP - 18 GPM

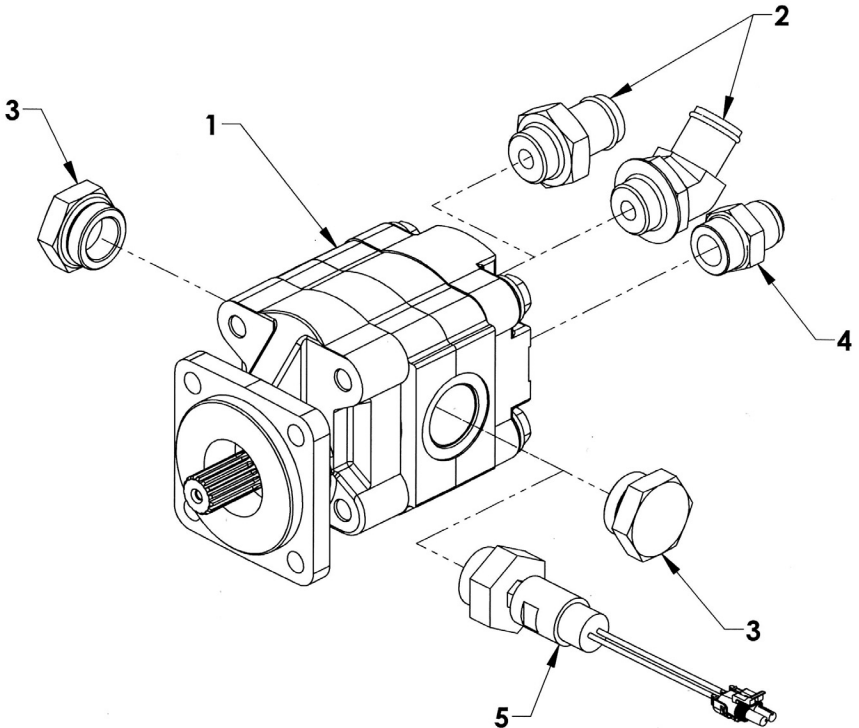

REF	PART #	DESCRIPTION	QPU
1	0320144	18 GPM , 1 IN.15 SPLINE SHAFT, SAE 4-BOLT FLANGE	1
2	S14604-20 x 16	#16-45 M O-RING x 1-1/4 M NIPPLE	1
	S14603- 20 x 26F	#16 M O-RING x 1-1/4 NIPPLE	1
3	77620	1-1/4 O-RING PLUG 900598-20	2
4	779A7	#16 M O-RING X 3/4 MJIC	1
5	0909434	PRESSURE TRANSDUCER (OPTIONAL)	1

Section V - PARTS

INBOARD OIL RESERVOIR GROUP

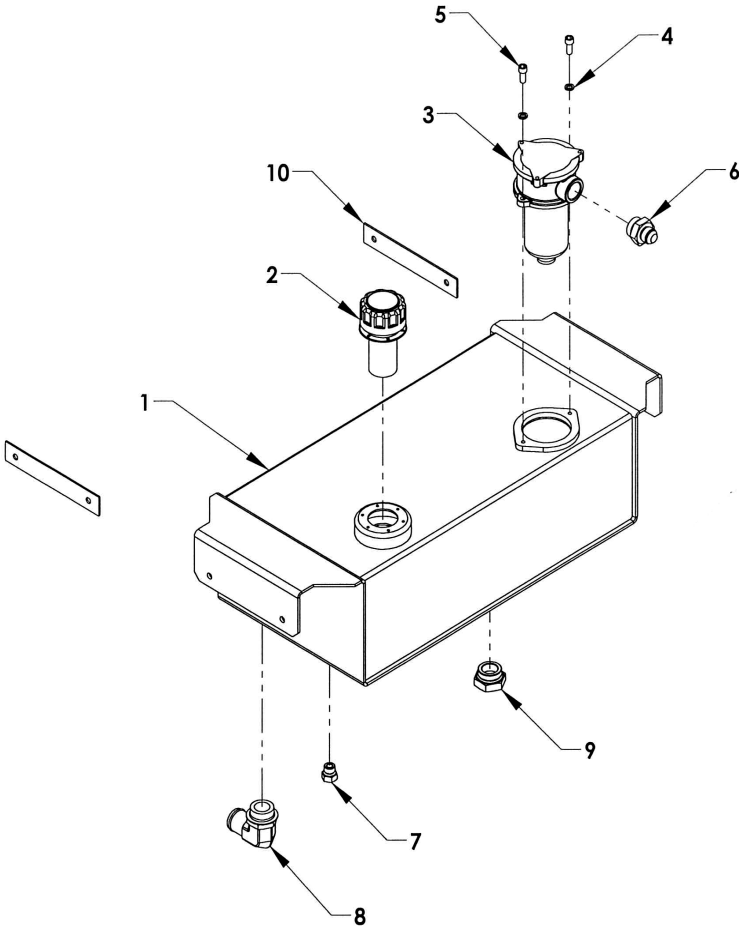

REF	PART #	DESCRIPTION	QPU
1	763100	INBOARD OIL RESERVOIR WELDMENT	1
2	76213	FILLER BREATHER CAP	1
3	76270	FILTER ASSEMBLY	1
	76271	REPLACEMENT FILTER ELEMENT	1
4	82220	LOCK WASHER 3/8 ZINC PLATE	2
5	812A8	BUTTON HEAD CAP SCREW 3/8-16 UNC x 7/8 SS	2
6	ADPTR202702-16x12	ADAPTOR 202702-16 x 12	1
7	ADPTR900598-8	ADAPTOR 900598-8 (DRAIN PLUG)	1
8	ADPTR2062-20 x 24H	20 x 24 SUCTION HOSE FITTING 90 DEGREES	1
9	ADPTR900598-20	ADAPTOR 900598-20 (PLUG)	1
10	763106	FRAME WIDTH SHIM	2

Section V- PARTS

OUTBOARD 24 GALLON HYDRAULIC TANK GROUP

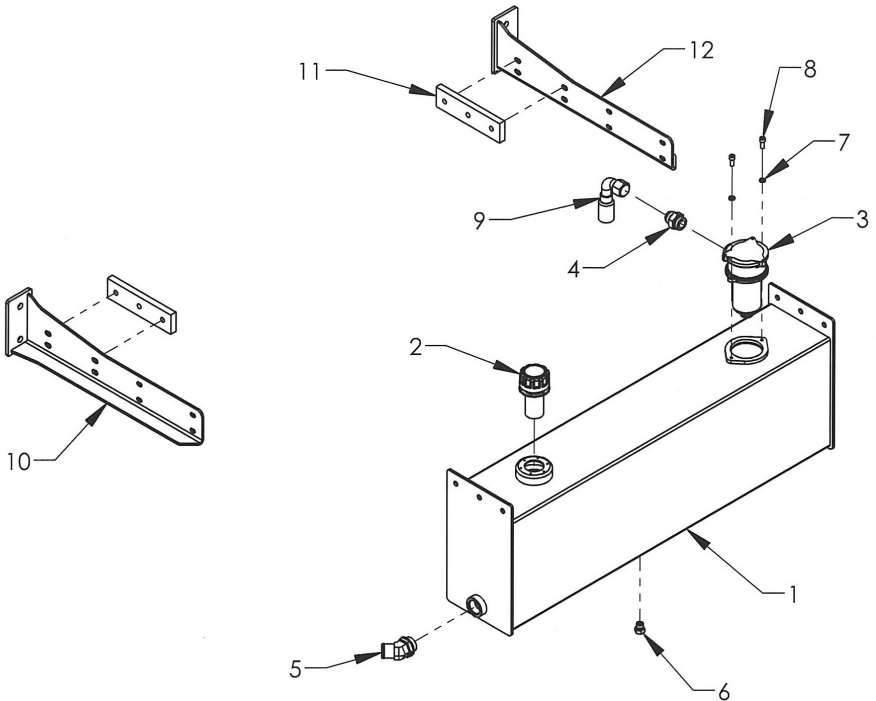

REF	PART #	DESCRIPTION	QPU
1	0809490	OUTBOARD 24 GALLON OIL RESERVOIR	1
2	76213G	FILLER/BREATHER CAP ASSEMBLY	1
3	76270	IN-TANK FILTER ASSEMBLY #16 SAE PORT	1
4	ADPTR202702 16x16	ADAPTOR 202702 16x16	1
5	ADPTR2061 20x24H	ADAPTOR 2061 20x24H	1
6	0403113	#8 O-RING PLUG - ADAPTOR 900598-8	1
7	82220	LOCK WASHER 3/8	2
8	81212	CAP SCREW 3/8-16 UNC x 7/8 SS	2
9	HOSEEND-16H-16JICF90	HOSE END - 16H - 16JICF90	1
10	37855R	UNV. TOOLBOX & OIL TNK MTG.BRKT-R	1
11	12826	TOOLBOX SHIM (FOR 49 IN. ALUM. BOX)	2
12	37855L	UNV. TOOLBOX & OIL TNK MTG BRKT-L	1

Section V - PARTS

9-SPOOL CONTROL STATION

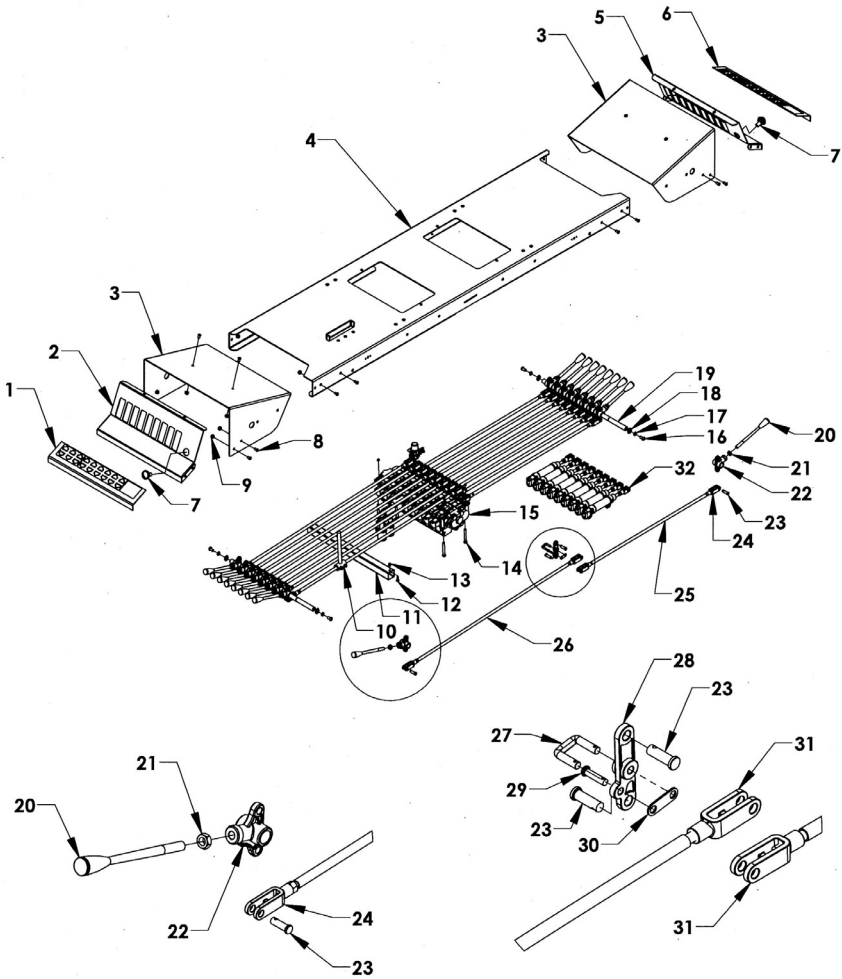

Section V - PARTS

9-SPOOL CONTROL STATION

REF. NO.	NO. REQ'D	PART NUMBER	DESCRIPTION
1	1	18219L	CONTROL PLACARD - LEFT
2	1	18142L	CONTROL PANEL - LEFT
3	2	18141	CONTROL HOOD
4	1	181289W	CONTROL BOX ARM WELDMENT - 79.5 IN.
5	1	18142R	CONTROL PANEL - RIGHT
6	1	18219R	CONTROL PLACARD - RIGHT
7	2	0320031	CONTROL LIGHT 2 WIRE
8	20		BOLT, BUTTON HEAD 5/16-18 UNC x 5/8
9	23		NYLON LOCK NUT 5/16-18 UNC
10	1	0809904	ANTI-TILT CONTROL ROD WELDMENT
11	1	18336	CONTROL STATION WIRE TUBE
12	4		BOLT, HHCS 1/4-20 UNC x 3/4
13	4		NYLON LOCK NUT 1/4-20 UNC
14	3		BOLT, HHCS 5/16 -18 UNC x 2-3/4
15	1	74119	VALVE BODY GRESSEN 9 SPOOL
16	4		BOLT, BUTTON HEAD 3/8-16 UNC x 3/4
17	4		LOCK WASHER - 3/8
18	4	86075E	SNAP RING 3/4 EXTERNAL
19	2	7A5753-20	CROSS ROD 3/4 X 20-3/4
20	6	0320048-BL	BLUE CONTROL HANDLE
	6	0320048-RD	RED CONTROL HANDLE
	2	0320048-GR	GREEN CONTROL HANDLE
	4	0320048-GY	GRAY CONTROL HANDLE
21	18		JAM NUT 1/2-13 UNC ZINC PLATED
22	18	7A1155	CONTROL HANDLE PIVOT BASE
23	36	84620	CLEVIS PIN - 3/8 x 1-1/8
24	18	84530	CLEVIS - RIGHT HAND THREAD
25	9	7A528W	CONTROL ROD 28-1/2
26	9	7A538W	CONTROL ROD 37-3/4
27	9	7A010LINK	CLEVIS LINK
28	9	7A121	BELL CRANK
29	9	84610	CLEVIS PIN, 1/4 x 15/16
30	9	7A010LINKPLATE	CLEVIS LINK PLATE
31	18	84540	CLEVIS - LEFT HAND THREAD
32	9	PC32B50	AIR CYLINDER - 2 IN. STROKE

Section V - PARTS

SERIES 20 HITCH COMPONENTS

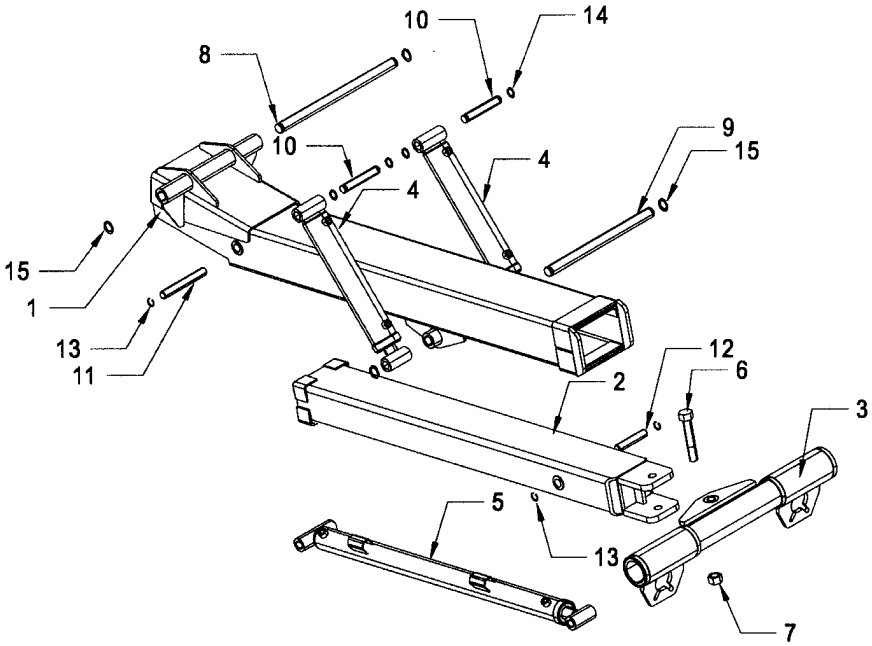

REF	PART #	DESCRIPTION	QPU
1	14240	HITCH TUBE-OUTER	1
2	14250	HITCH TUBE-INNER	1
3	15110	TOWBAR	1
4	72135	HITCH LIFT CYLINDER	2
5	72132	HITCH EXTENSION CYLINDER	1
6	15022	TOWBAR BOLT	1
7	83610	7/8 NYLON LOCK NUT	1
8	14518	HITCH/WHEEL LIFT PIVOT PIN	1
9	14519	LIFT CYLINDER PIVOT PIN	1
10	17190	CYLINDER BASE PIN .980 x 5-7/8 SPRING	2
11	72936	CYLINDER BASE PIN .980 x 7-1/8	1
12	72941	CYLINDER ROD PIN .980 x 4-3/4	1
13	86100I	SNAP-RING 1.00 INTERNAL	4
14	86100E-1	SNAP-RING 1.00 EXTERNAL-7200	4
15	86125E-1	SNAP-RING 1.25 EXTERNAL-7200	4

Section V - PARTS

HYDRAULIC STABILIZER COMPONENTS

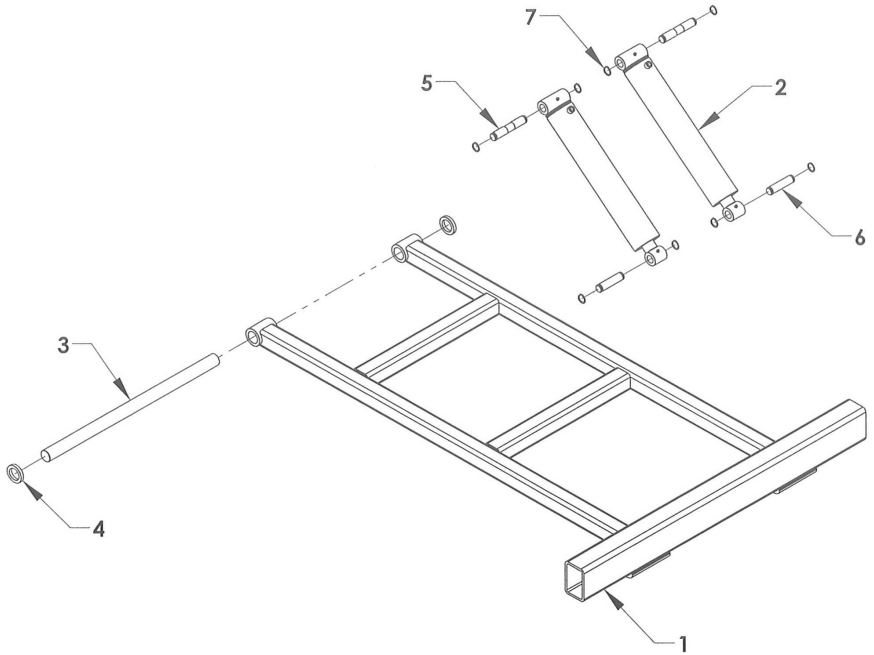

REF	PART #	DESCRIPTION	QPU
1	163720	STABILIZER TUBE	1
2	72118	STABILIZER CYLINDER - SHORT 28-1/8	2
	72118	STABILIZER CYLINDER - LONG 29-5/8	2
3	16340020	STABILIZER PIVOT PIN	1
4	16341	PIVOT PIN WELD-ON RING	2
5	16363	CYLINDER BASE PIN 1.230x 6-7/8	2
6	16362	CYLINDER ROD PIN 1.230 x 5	2
7	86125E	SNAP-RING 1-1/4 EXTERNAL	8

Section V - PARTS

WHEEL LIFT

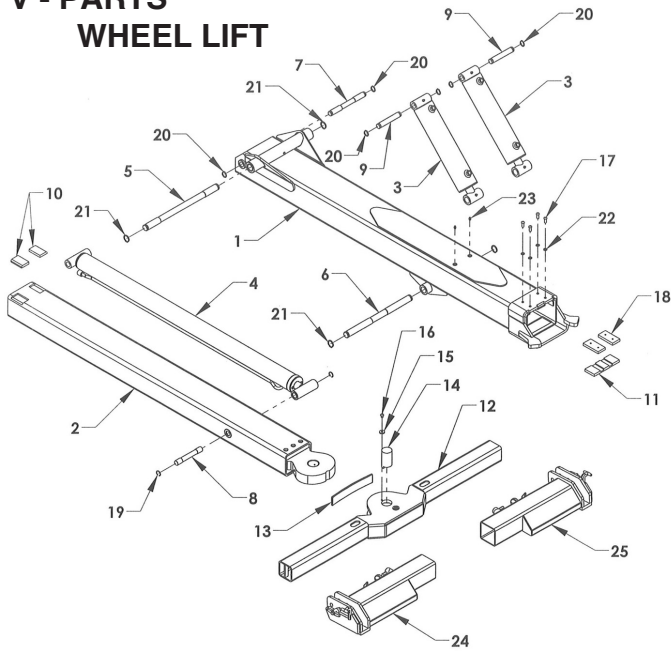

REF	PART #	DESCRIPTION	QPU
1	102412	WHEEL LIFT TUBE - OUTER	1
2	10244	WHEEL LIFT TUBE - INNER	1
3	72135	WHEEL LIFT LIFT CYLINDER	2
4	72127	WHEEL LIFT EXTENSION CYLINDER	1
5	14518	WHEEL LIFT PIVOT PIN	1
6	14519	LIFT CYLINDER PIVOT PIN	1
7	729352	EXTENSION CYLINDER BASE PIN .980 x 9-1/2	1
8	72940	EXTENSION CYLINDER ROD PIN .980 x 6-11/16	1
9	17190	LIFT CYLINDER BASE PIN .980 x 5-7/8 SPRING	2
10	65613	NYLATRON WEAR PAD	2
11	65611	NYLATRON WEAR PAD-GROOVED	1
12	65515	CROSSBAR	1
13	65228	LEAF SPRING	1
14	65435	CROSSBAR PIVOT PIN	1
15	82212	WASHER 3/8 I.D. x 1 O.D.	1
16	812A5	SOCKET HEAD BUTTON - 3/8 x 1/2	1
17	812A9	SOCKET HEAD BUTTON - 3/8 x 1	4
18	63595H	NYLATRON WEAR PAD	2
19	86100I	SNAP-RING 1.00 INTERNAL	2
20	86100E	SNAP-RING 1.00 EXTERNAL	6
21	86125E	SNAP-RING 1.25 EXTERNAL	4
22	82220	LOCK WASHER - 3/8	4
23	7B120	GREASE FITTING - 1/4	2
24	65265L	WHEEL GRID - LEFT	1
25	65265R	WHEEL GRID - RIGHT	1

Section V - PARTS

WHEEL LIFT/RELEASABLE L-ARMS

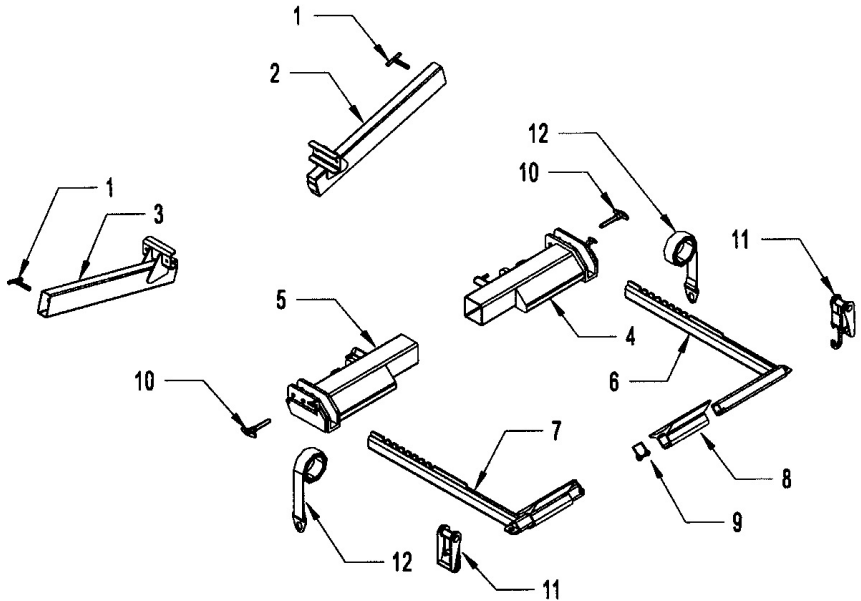

REF	PART #	DESCRIPTION	QPU
1	12614	FRICITION PIN L-ARM STORAGE TUBE	2
2	12615R	L-ARM STORAGE TUBE - RIGHT	1
3	12615L	L-ARM STORAGE TUBE - LEFT	1
4	65265R	WHEEL GRID - RIGHT	1
5	65265L	WHEEL GRID - LEFT	1
6	65250R	WHEEL RETAINER - RIGHT	1
7	65250L	WHEEL RETAINER - LEFT	1
8	65245	REMOVABLE PAN	2
9	84911	5/16 SAFETY SNAP PIN	2
10	84921	T-PIN WITH LANYARD	2
11	65280A	RATCHET	2
12	65285	WHEEL STRAP	2

Section V - PARTS

PIVOT L-ARM RECEIVER GROUP (OPTIONAL)

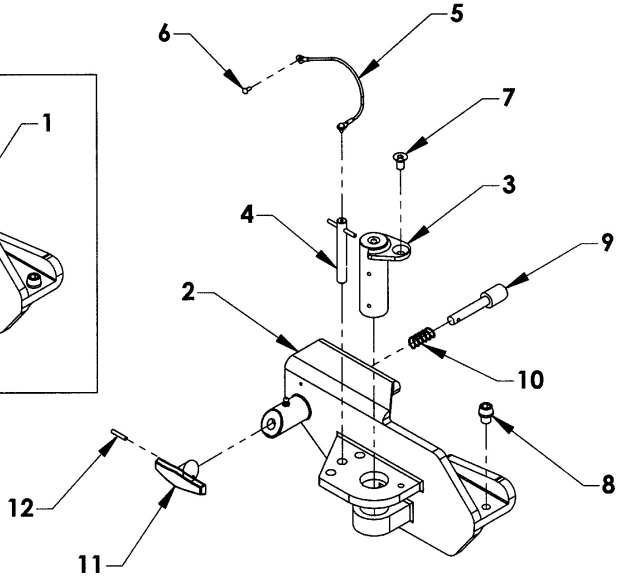
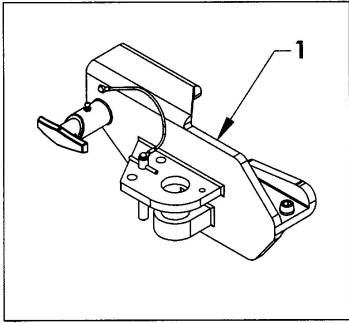

REF	PART #	DESCRIPTION	QPU
1	659820L	PIVOT L-ARM RECEIVER GROUP-LEFT	1
	659820R	PIVOT L-ARM RECEIVER GROUP-RIGHT (SHOWN)	1
2	659821L	PIVOT L-ARM RECEIVER CASTING-LEFT	1
	659821R	PIVOT L-ARM RECEIVER CASTING-RIGHT (SHOWN)	1
3	659822	L--ARM RECEIVER CASTING PIVOT PIN	1
4	659826	PIVOT LOCK PIN	1
5	659827	LANYARD	1
6	85016	RIVET	1
7	81225	FLAT HEAD SOCKET CAP SCREW 3/8-16 UNC X 1/2	1
8	81226	TAPERED SOCKET CAP SCREW 1/2-13 UNC X 1/2	1
9	659824	7/8 CAM PIN	1
10	89100	CAM PIN SPRING	1
11	659825	T-HANDLE	1
12	84675	ROLL PIN 3/16 X 1	1

Section V - PARTS

PIVOT WHEEL GRIDS AND L-ARMS

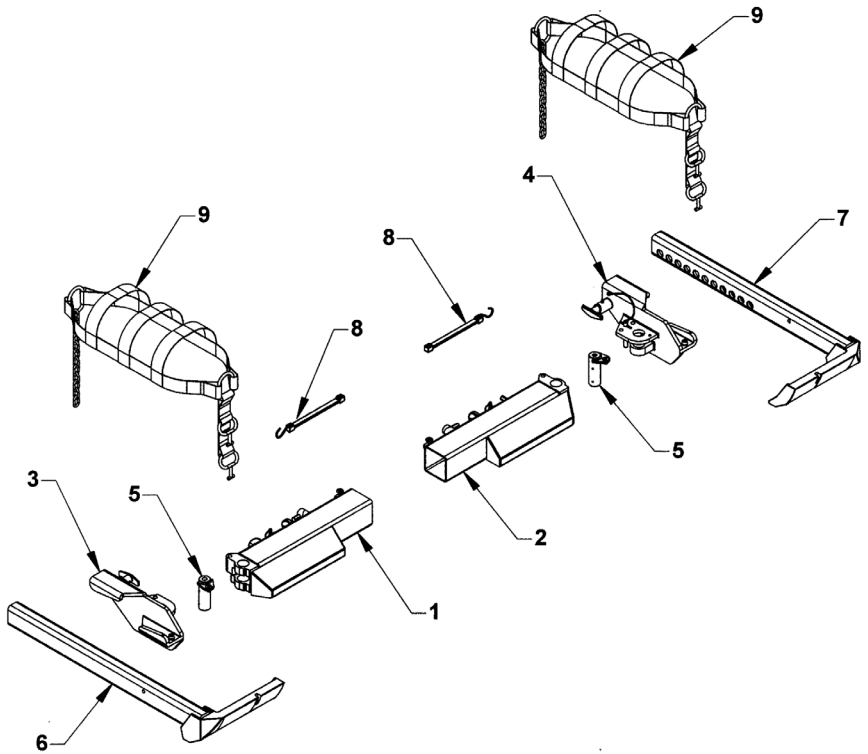

REF	PART #	DESCRIPTION	QPU
1	659811L	PIVOT WHEEL GRID-LEFT	1
2	659811R	PIVOT WHEEL GRID-RIGHT	1
3	659820L	PIVOT L-ARM RECEIVER GROUP-LEFT	1
4	659820R	PIVOT L-ARM RECEIVER GROUP-RIGHT	1
5	659822	L-ARM RECEIVER CASTING PIVOT PIN	1
6	659830L	LEFT ALUMINUM L-ARM	1
7	659830R	RIGHT ALUMINUM L-ARM	1
8	AA009G	RUBBER TENSION STRAP WITH S-HOOK	2
9	65286	BASKET STRAP-CAR	2
	65287	BASKET STRAP-TRUCK	2

Section V - PARTS

AUTOGRIP II UNDERLIFT

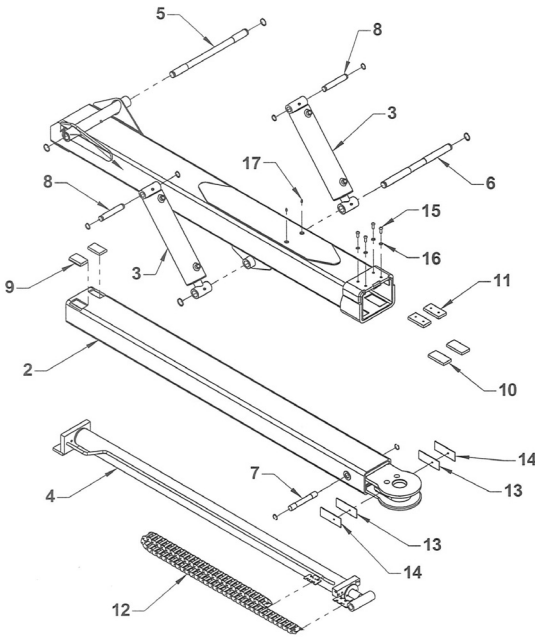

REF	PART #	DESCRIPTION	QPU
1	102512	OUTER BOOM TUBE	1
2	102522	INNER BOOM TUBE	1
3	72133	LIFT CYLINDER SERIES 10	1
	72135	LIFT CYLINDER SERIES 12/14	2
4	72136	EXTENSION CYLINDER	1
5	14518	WHEEL LIFT PIVOT PIN	1
	86125E	SNAP-RING 1.25 EXTERNAL	2
6	14519	LIFT CYLINDER PIVOT PIN	1
	86125E	SNAP-RING 1.25 EXTERNAL	2
7	72940	EXTENSION CYLINDER PIN .980 x 6-5/8	1
	86100I	SNAP-RING 1.00 INTERNAL	2
8	17190	LIFT CYLINDER PIN .980 x 5-7/8	2
	86100E	SNAP-RING 1.00 INTERNAL	4
9	65613	NYLATRON WEAR PAD	2
10	63595	NYLATRON WEAR PAD	1
11	63595H	NYLATRON WEAR PAD	1
12	69757	HOSE TRACK	1
13	64304R	RUBBER PAD	2
14	64304C	HOSE CLAMP PLATE	2
	81103	BOLT 1/4-20 x 3/4	2
15	812AP	SOCKET HEAD BUTTON - 3/8 x 1	4
16	82220	LOCK WASHER - 3/8	4
17	7B120	GREASE FITTING - 1/4	2

Section V - PARTS

AUTOGRIP II COMPONENTS

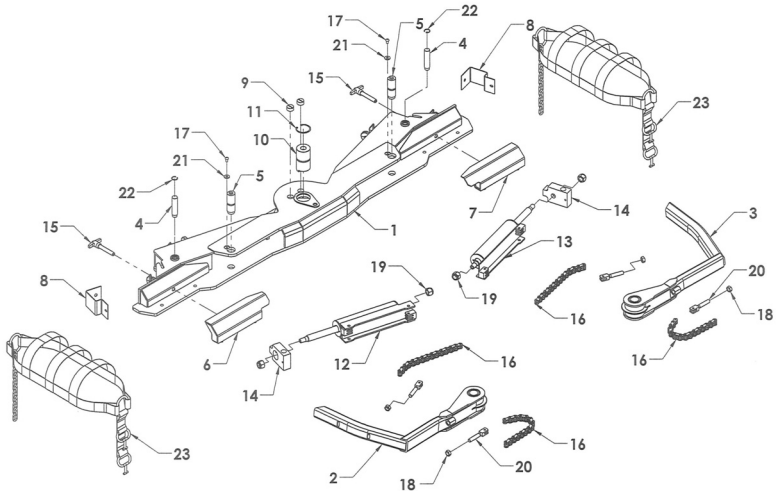

REF NO.	PART NUMBER	DESCRIPTION	QTY
1	644002	CROSSBAR WELDMENT	
2	644352CL	WHEEL RETAINER - LEFT	1
3	644352CR	WHEEL RETAINER - RIGHT	1
4	644432	WHEEL RETAINER CYLINDER PIN	2
5	644452	ARM PIVOT PIN	2
6	697402L	WHEEL SPACER - LEFT	1
7	697402R	WHEEL SPACER - RIGHT	1
8	644292	HOSE GUARD	2
9	64327	SCREW-PLUG CROSSBAR DETENT	2
10	644402	CROSSBAR PIN	1
11	862501	SNAP RING 2.500 INCH INTERNAL	1
12	720152L	WHEEL RETAINER CYLINDER - LEFT	1
13	720152R	WHEEL RETAINER CYLINDER - RIGHT	1
14	727162	L-ARM CYLINDER END BLOCK	2
15	84291	T-PIN 5/8 x 3	2
16	87440	AUTOGRIP ARM CHAIN	4
	81127	5/16 x 1-1/4 SHOULDER SHCS 1/4-20 UNC	4
	83105	1/4-20 UNC NYLON LOCK NUT	4
17	812A5	3/8 ALLEN BOLT	2
18	83411	5/8 NYLON LOCK NUT	4
19	83520	3/4 NYLON LOCK NUT	2
20	64441	CHAIN CLEVIS	4
	81126	5/16 x 1 SHOULDER SHCS 1/4-20 UNC	4
	83105	1/4-20 UNC NYLON LOCK NUT	4
21	82110	5/16 FLAT WASHER	2
22	861001	SNAP-RING 1.000 INCH INTERNAL	2
23	65286	BASKET TIRE STRAP - AUTO	2
	66287	BASKET TIRE STRAP - TRUCK	2

Section V - PARTS

JXL CAB PROTECTOR

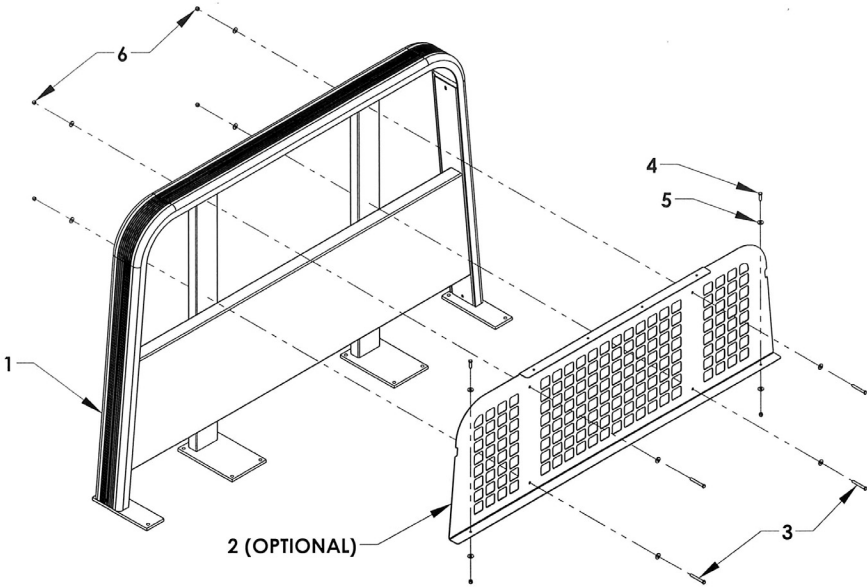

REF	PART #	DESCRIPTION	QPU
1	35A044	JXL CAB PROTECTOR - 44 INCHES	1
	35A046	JXL CAB PROTECTOR - 46 INCHES	1
	35A048	JXL CAB PROTECTOR - 48 INCHES	1
	35A050	JXL CAB PROTECTOR - 50 INCHES	1
	35A052	JXL CAB PROTECTOR - 52 INCHES	1
	35A056	JXL CAB PROTECTOR - 56 INCHES	1
	35A060	JXL CAB PROTECTOR - 60 INCHES	1
	2	35AS44	JXL WINDOW SCREEN PANEL - 44 INCHES
35AS46		JXL WINDOW SCREEN PANEL - 46 INCHES	1
35AS48		JXL WINDOW SCREEN PANEL - 48 INCHES	1
35AS50		JXL WINDOW SCREEN PANEL - 50 INCHES	1
35AS52		JXL WINDOW SCREEN PANEL - 52 INCHES	1
35AS56		JXL WINDOW SCREEN PANEL - 56 INCHES	1
35AS60		JXL WINDOW SCREEN PANEL - 60 INCHES	1
3	81275	BOLT 3/8-16 UNC x 3 GR 5 ZINC PLATED	4
4	81232	BOLT 3/8-16 UNC x 1-1/4 GR 5 ZINCH PLATED	2
5	82210	FLAT WASHER, 3/8 ZINC PLATED	12
6	83211	NYLON LOCK NUT 3/8-16 UNC, ZINC PLATED	6

Section V - PARTS

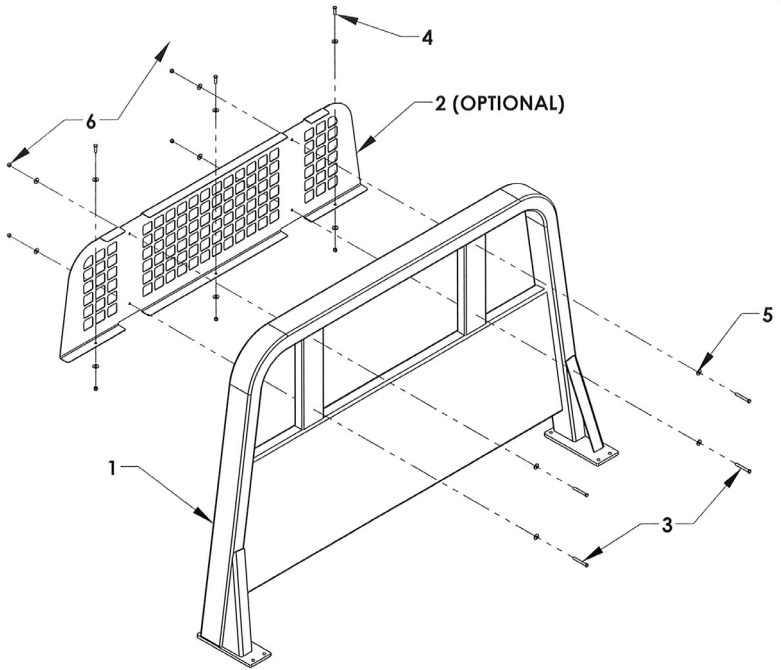

MODEL F CAB PROTECTOR (SHORT FOOT)



REF	PART #	DESCRIPTION	QPU
1	3512046	MODEL F CAB PROTECTOR - 46 INCHES	1
	3512048	MODEL F CAB PROTECTOR - 48 INCHES	1
	3512050	MODEL F CAB PROTECTOR - 50 INCHES	1
	3512052	MODEL F CAB PROTECTOR - 52 INCHES	1
	3512056	MODEL F CAB PROTECTOR - 56 INCHES	1
	3512060	MODEL F CAB PROTECTOR - 60 INCHES	1
	3512063	MODEL F CAB PROTECTOR - 63 INCHES	1
	3512068	MODEL F CAB PROTECTOR - 68 INCHES	1
2	35246WS	MODEL F WINDOW SCREEN PANEL - 46 INCHES	1
	35248WS	MODEL F WINDOW SCREEN PANEL - 48 INCHES	1
	35250WS	MODEL F WINDOW SCREEN PANEL - 50 INCHES	1
	35252WS	MODEL F WINDOW SCREEN PANEL - 52 INCHES	1
	35256WS	MODEL F WINDOW SCREEN PANEL - 56 INCHES	1
	35260WS	MODEL F WINDOW SCREEN PANEL - 60 INCHES	1
	35263WS	MODEL F WINDOW SCREEN PANEL - 63 INCHES	1
35268WS	MODEL F WINDOW SCREEN PANEL - 68 INCHES	1	
3	81275	BOLT 3/8-16 UNC x 3 GR 5 ZINC PLATED	4
4	81232	BOLT 3/8-16 UNC x 1-1/4 GR 5 ZINCH PLATED	3
5	82210	FLAT WASHER, 3/8 ZINC PLATED	14
6	83211	NYLON LOCK NUT 3/8-16 UNC, ZINC PLATED	7

Section V - PARTS

REMOVABLE TUBE SIDE RAILS

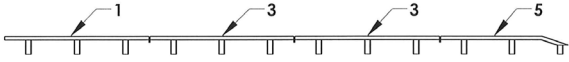
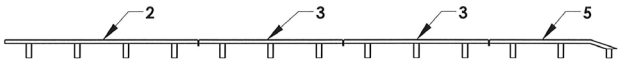
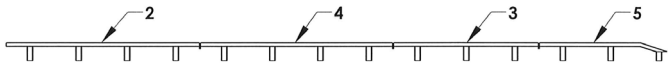
BED LENGTH	REMOVABLE RAIL COMBINATIONS
21 TO 22 FT	
23 TO 24 FT	
25 TO 26 FT	
27 TO 28 FT	
29 TO 30 FT	

REF	PART #	DESCRIPTION	QPU
1	346071F	FRONT REMOVABLE TUBE RAIL - 3 POST	SEE CHART
2	346095F	FRONT REMOVABLE TUBE RAIL - 4 POST	SEE CHART
3	346071M	MIDDLE REMOVABLE TUBE RAIL - 3 POST	SEE CHART
4	346095M	MIDDLE REMOVABLE TUBE RAIL - 4 POST	SEE CHART
5	346064	REAR REMOVABLE TUBE RAIL - 3 POST	SEE CHART

Section V - PARTS

TAIL LIGHT COMPONENTS

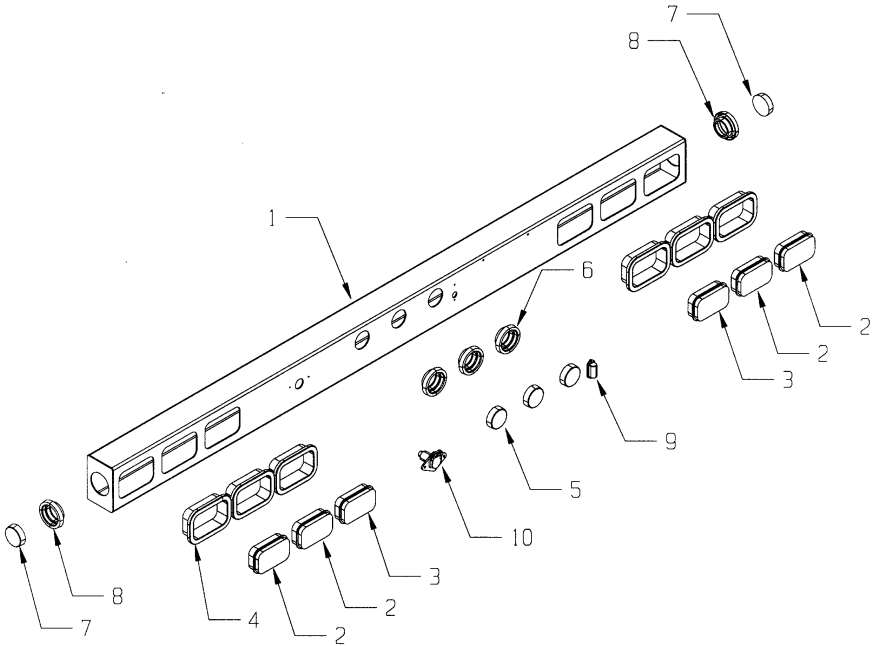

REF	PART #	DESCRIPTION	QPU
1	19500	TAIL LIGHT HOUSING	1
	19510	TAIL LIGHT HOUSING-HITCH	1
2	96500	LIGHT-TAIL, STOP, TURN MODEL 45202R	4
3	95500	LIGHT BACKUP MODEL 45204	2
4	96550	GROMMET MODEL 45700	6
5	94500	ICC LIGHT MODEL 40	3
6	94550	GROMMET MODEL 30	3
7	93100R	MARKER LIGHT MODEL 10	2
8	93150	GROMMET MODEL 10	2
9	97150	LIGHT-LICENSE PLATE	1
10	98400	TOW LIGHT PLUG-4 PRONG	1
	98600	TOW LIGHT PLUG-6 PRONG	1

Section V - PARTS

MUDFLAP COMPONENTS

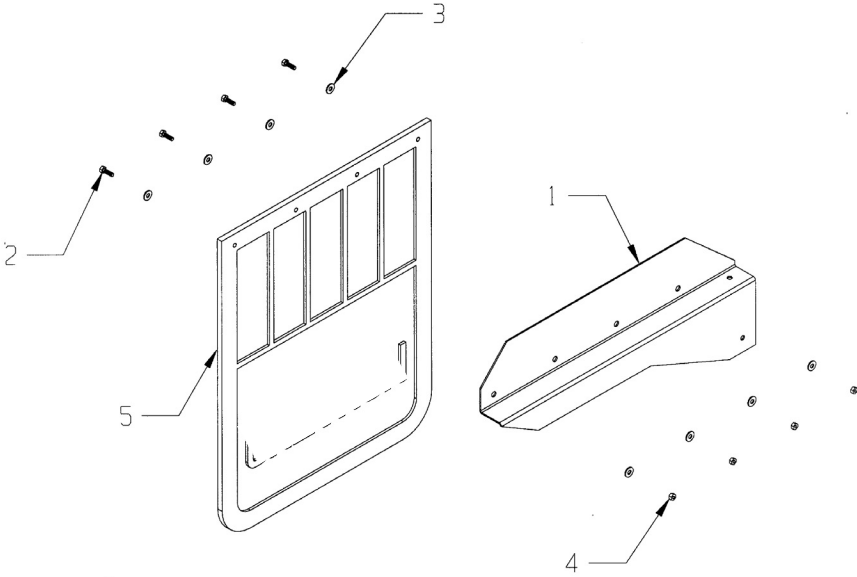

REF	PART #	DESCRIPTION	QPU
1	12350L	MUDFLAP MOUNTING BRACKET	1
	12350R	MUDFLAP MOUNTING BRACKET	1
2	81110	5/16 x 1 BOLT	8
3	82110	5/16 FLAT WASHER	16
4	83125	5/16 NYLON LOCK NUT	8
5	A1030	MUDFLAP 24 x 30	2

Section V - PARTS

RAMSEY WINCH GROUP

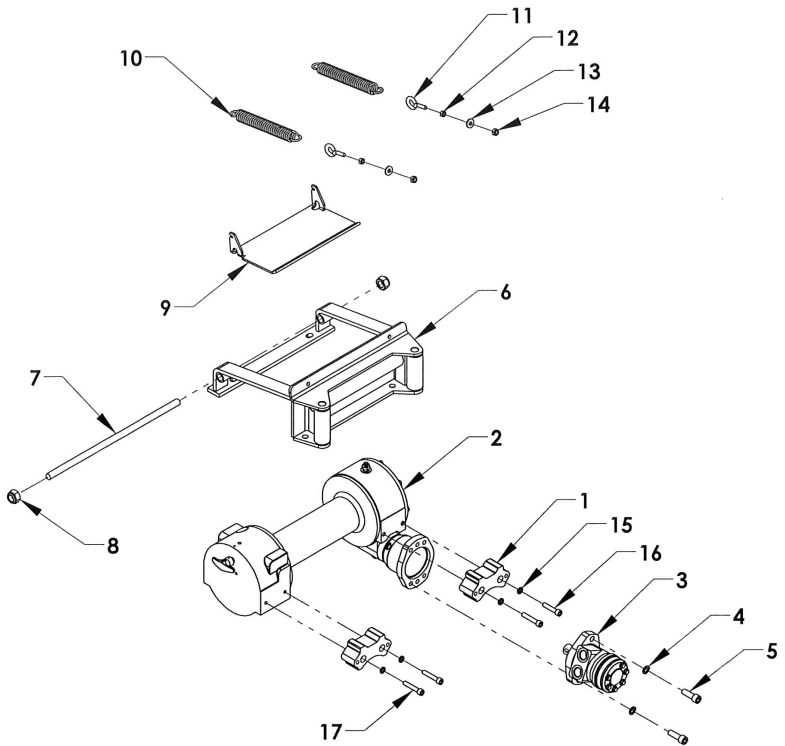

REF	PART #	DESCRIPTION	QPU
1	31A05	RAMSEY WINCH MOUNTING ADAPTOR BLOCK	2
2	71104	RAMSEY WINCH - 8,000 LBS. 11 INCH DRUM	1
	71104A	RAMSEY WINCH - 8,000 LBS. 11 INCH DRUM, AIRSHIFT	1
3	71901	RAMSEY WINCH MOTOR	1
4	82320	LOCK WASHER 1/2 ZINC PLATED	2
5	81430	BOLT 1/2-13 UNC x 1-1/2 ZINC PLATED	2
6	A90140	ROLLER GUIDE	1
7	A9020	TENSION PLATE HINGE PIN	1
8	83411	NYLON LOCK NUT 5/8-11 UNC ZINC PLATED	2
9	A9021	TENSION PLATE, 8 INCH DRUM	1
10	A9018S	TENSION SPRING 40 LB/INCH	2
11	81180	EYE-BOLT 5/16-18 UNC x 1 ZINC PLATED	2
12	82110	FLAT WASHER 5/16 ZINC PLATED	2
13	83125	NYLON LOCK NUT 5/16-18 UNC ZINC PLATED	2
14	83120	NUT 5/16-18 UNC ZINC PLATED	2
15	82220	LOCK WASHER 3/8 ZINC PLATED	4
16	81243	SOCKET HEAD CAP SCREW 3/8-16 UNC x 1-3/4 SS	1
17	81244	SOCKET HEAD CAP SCREW 3/8-16 UNC x 2 SS	3

Section V - PARTS

RAMSEY WINCH CLUTCH HANDLE

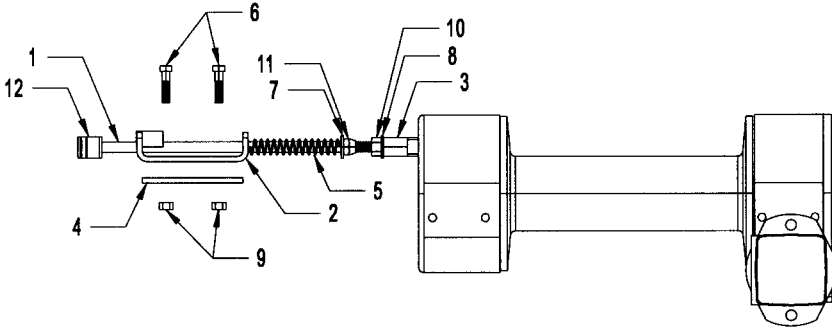

REF	PART #	DESCRIPTION	QPU
1	71810	REMOTE CLUTCH ROD	1
2	71811	REMOTE CLUTCH MOUNTING BRACKET	1
3	71812	1/2-13 UNC COUPLING	1
4	71813	1/4 UHMW SHIM (FOR STEEL CARRIERS)	1
5	71815	REMOTE CLUTCH SPRING	1
6	81243	3/8 x 1-3/4 UNC BOLT	2
7	82310	1/2 FLAT WASHER	1
8	82320	1/2 LOCK WASHER	1
9	83211	3/8-13 UNC NYLON LOCK NUT	2
10	83311	1/2-13 UNC NUT	1
11	83321	1/2-13 UNC NYLON LOCK NUT	1
12	88105	T-HANDLE	1
	84665	5/32 x 1 PLATED ROLL PIN	1

Section V - PARTS WARN WINCH GROUP

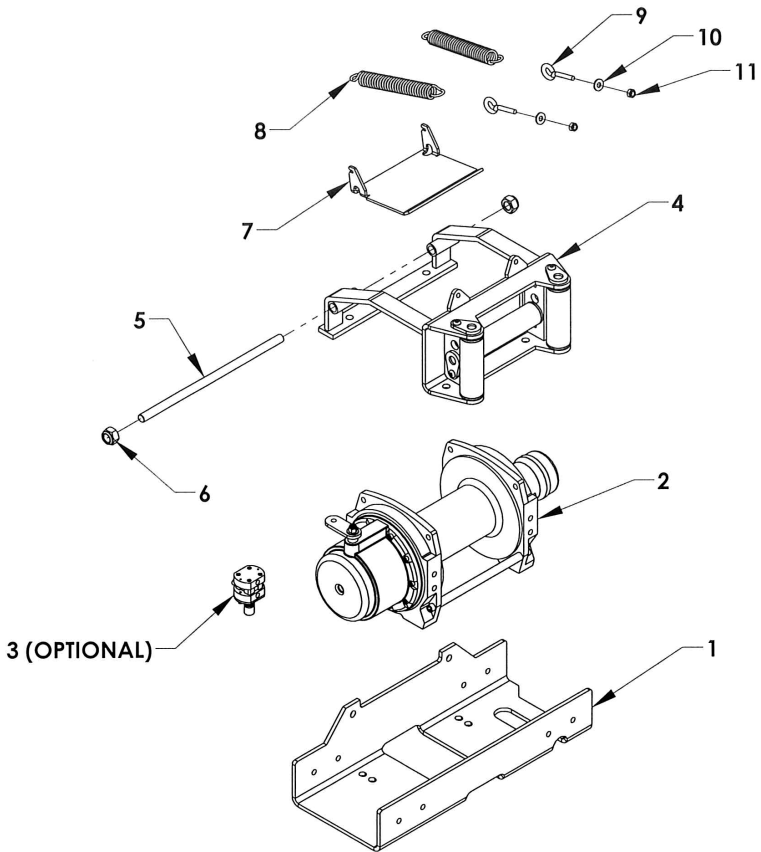

REF	PART #	DESCRIPTION	QPU
1	31025	WARN WINCH MOUNTING PLATE	1
2	71109	WARN WINCH - 9,000 LBS. 8 INCH DRUM, OVERWIND	1
	71112	WARN WINCH - 12,000 LBS. 8 INCH DRUM, OVERWIND	1
	71115	WARN WINCH - 15,000 LBS. 8 INCH DRUM, OVERWIND	1
3	71885	AIR-SHIFT CLUTCH CYLINDER	1
4	A90209	ROLLER GUIDE	1
5	A9008	TENSION PLATE HINGE PIN	1
6	83411	NYLON LOCK NUT 5/8-11 UNC ZINC PLATED	2
7	A9009N	TENSION PLATE, 8 INCH DRUM	1
8	A9018S	TENSION SPRING 40 LB/INCH	2
9	81181	EYE-BOLT 5/16-18 UNC x 2 ZINC PLATED	2
10	82110	FLAT WASHER 5/16 ZINC PLATED	2
11	83125	NYLON LOCK NUT 5/16-18 UNC ZINC PLATED	2

Section V - PARTS

WARN WINCH REMOTE CLUTCH

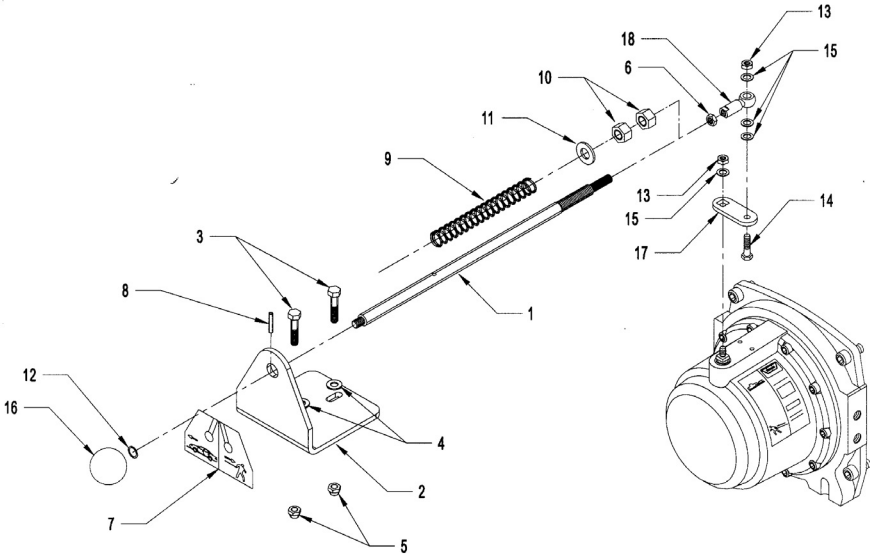

REF	MFGR	PART #	DESCRIPTION	QPU
1	MILLER	71873	REMOTE CLUTCH ROD	1
2	MILLER	71874	REMOTE HANDLE BRACKET	1
3	MILLER	81122	5/16-18 UNC x 1-1/2 BOLTS	2
4	MILLER	82130	5/16 FLAT WASHER	2
5	MILLER	83125	5/16-18 UNC NYLON LOCK NUT	2
6	MILLER	83215	3/8-24 UNF NUT	1
7	MILLER	AA870	HANDLE BRACKET DECAL	1
8	MILLER	84680	3/16 x 1 SPLIT PIN	1
9	MILLER	71875	SPRING	1
10	MILLER	83310	1/2-13 UNC NUT	2
11	MILLER	82310	1/2 FLAT WASHER	1
12	WARN	WW1146	3/8 STAR WASHER	1
13	WARN	WW6779	3/8-16 UNC NYLON LOCK NUT	2
14	WARN	WW8160	3/8-16 UNC x 1-1/2 BOLT	1
15	WARN	WW11524	3/8 FLAT WASHER	4
16	WARN	WW15604	CLUTCH ROD KNOB	1
17	WARN	WW25364	CLUTCH SHIFTER PLATE	1
18	WARN	WW25671	BALL JOINT ROD END	1

Section V - PARTS

HYDRAULIC SLIDEWINDER

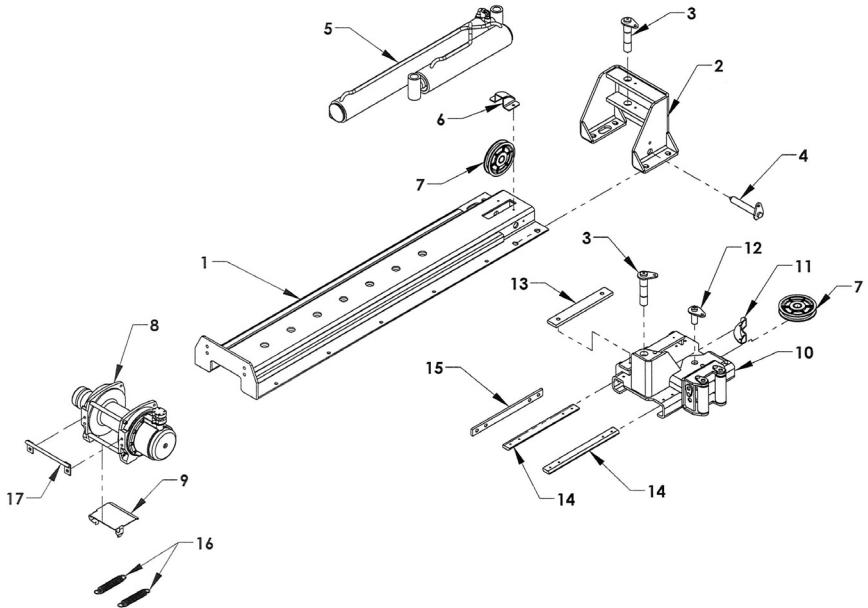

REF	PART #	DESCRIPTION	QPU
1	315210	SLIDE TRACK	1
2	315360	CYLINDER MOUNTING BRACKET	1
3	315335	CYLINDER MOUNTING PIN	2
4	315235	PULLEY PIN	1
5	72A30040	SLIDEWINDER CYLINDER	1
6	315225	CABLE GUIDE	1
7	69125	6 x 1 PULLEY	2
8	711096	SERIES 9 WINCH - 6.5 INCH DRUM	1
	711126	SERIES 12 WINCH - 6.5 INCH DRUM	1
9	A90065	CABLE TENSIONER PLATE	1
10	315380	SLIDE CARRIAGE	1
11	315325	CABLE GUIDE	1
12	315330	PULLEY PIN	1
13	315321	CYLINDER SLIDE PAD	1
14	315320	SLIDE PAD	2
15	315323	FRONT SLIDE PAD	1
16	A9018S	CABLE TENSIONER SPRING	2
17	7189065	AIR LINE TRANSFER BRACKET	1

Section V - PARTS

MANUAL SLIDEWINDER

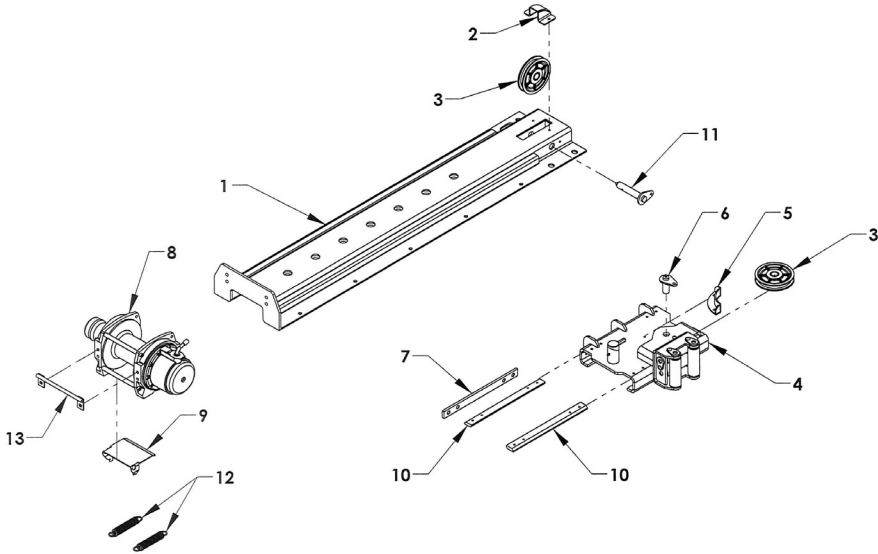

REF	PART #	DESCRIPTION	QPU
1	315210	SLIDE TRACK - SHORT	1
2	315225	CABLE GUIDE	1
3	69125	6 x 1 PULLEY	2
4	315310	SLIDE CARRIAGE	1
5	315325	CABLE GUIDE	1
6	315330	PULLEY PIN	1
7	315323	FRONT SLIDE PAD	1
8	711096	SERIES 9 WINCH - 6.5 INCH DRUM	1
	711126	SERIES 12 WINCH - 6.5 INCH DRUM	1
9	A90065	CABLE TENSIONER PLATE	1
10	315320	SLIDE PAD	2
11	315230	PULLEY PIN	1
12	A9018S	CABLE TENSIONER SPRING	2
13	7189065	AIR LINE TRANSFER BRACKET	1

Section V - PARTS

33" ALUMINUM TOOLBOX - 377000

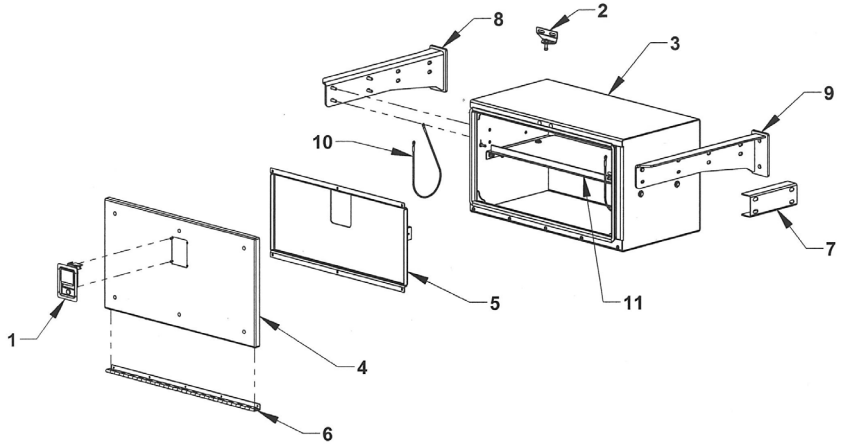

REF	PART #	DESCRIPTION	QPU
1	54658	ROTARY PADDLE LATCH	1
	54657	GASKET FOR PADDLE LATCH	1
	81111	#8-32 X 1/2 STAINLESS ONE WAY SCREW	4
	83111	#8-32 STAINLESS KEPT NUT	4
2	376182	STRIKER PIN MOUNTING PLATE	1
	54659	STRIKER PIN	1
	81115	STAINLESS CARRIAGE BOLT 5/16-18 x 3/4	2
	82110	FLAT WASHER 5/16	4
	82130	LOCK WASHER 5/16	2
	83110	NUT 5/16-18	2
	83125	NYLON LOCK NUT 5/16-18	1
	3	377100W	BOX WELDMENT
4	37741	DOOR WELDMENT	1
	37740	DOOR ASSEMBLY	1
	81100	STAINLESS CARRIAGE BOLT 1/4-20 x 3/4	6
	83105	NYLON LOCK NUT 1/4-20	6
	5	37744	DOOR REINFORCEMENT
6	37735	HINGE	1
	811014	SS SOCKET BUTTON HEAD BOLT 1/4-20 x 7/8	2
	811012	SS SOCKET BUTTON HEAD BOLT 1/4-20 x 3/4	3
	811010	SS SOCKET BUTTON HEAD BOLT 1/4-20 x 5/8	5
	83105	NYLON LOCK NUT 1/4-20	10
7	37760	TANDEM BOX SPACER CHANNEL (OPTIONAL)	1
8	37855L	TANK AND TOOLBOX MOUNTING BRACKET-LEFT	1
9	37855R	TOOLBOX MOUNTING BRACKET-RIGHT	1
10	5A221	LANYARD-21 INCH	2
11	37770	SHELF	1

Section V - PARTS

49" ALUMINUM TOOLBOX - 378000

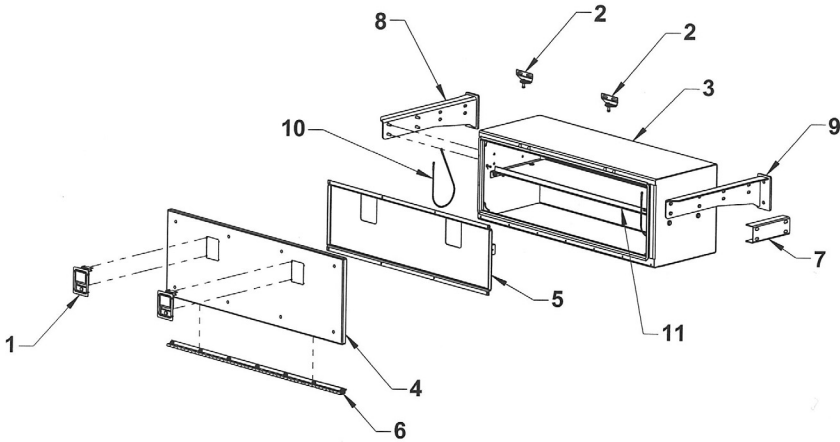

REF	PART #	DESCRIPTION	QPU	
1	54658	ROTARY PADDLE LATCH	1	
	54657	GASKET FOR PADDLE LATCH	1	
	81111	#8-32 X 1/2 STAINLESS ONE WAY SCREW	4	
	83111	#8-32 STAINLESS KEPT NUT	4	
2	376182	STRIKER PIN MOUNTING PLATE	1	
	54659	STRIKER PIN	1	
	81115	STAINLESS CARRIAGE BOLT 5/16-18 x 3/4	2	
	82110	FLAT WASHER 5/16	4	
	82130	LOCK WASHER 5/16	2	
	83110	NUT 5/16-18	2	
	83125	NYLON LOCK NUT 5/16-18	1	
3	378100W	BOX WELDMENT	1	
4	37741	DOOR WELDMENT	1	
	37740	DOOR ASSEMBLY	1	
	81100	STAINLESS CARRIAGE BOLT 1/4-20 x 3/4	6	
	83105	NYLON LOCK NUT 1/4-20	6	
5	37744	DOOR REINFORCEMENT	1	
	6	37735	HINGE	1
		811014	SS SOCKET BUTTON HEAD BOLT 1/4-20 x 7/8	2
		811012	SS SOCKET BUTTON HEAD BOLT 1/4-20 x 3/4	3
		811010	SS SOCKET BUTTON HEAD BOLT 1/4-20 x 5/8	5
83105	NYLON LOCK NUT 1/4-20	10		
7	37760	TANDEM BOX SPACER CHANNEL (OPTIONAL)	1	
8	37855L	TANK AND TOOLBOX MOUNTING BRACKET-LEFT	1	
9	37855R	TANK AND TOOLBOX MOUNTING BRACKET-RIGHT	1	
10	5A221	LANYARD-21 INCH	2	
11	37770	SHELF	1	

Section V - PARTS

65" ALUMINUM TOOLBOX - 379000

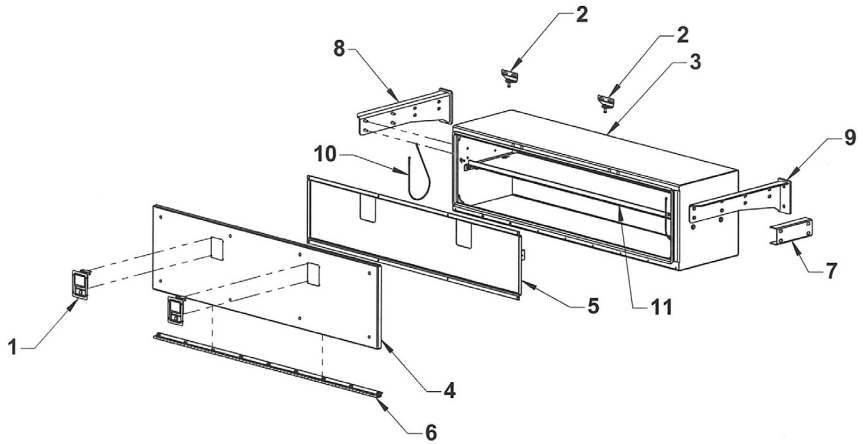

REF	PART #	DESCRIPTION	QPU
1	54658	ROTARY PADDLE LATCH	1
	54657	GASKET FOR PADDLE LATCH	1
	81111	#8-32 X 1/2 STAINLESS ONE WAY SCREW	4
	83111	#8-32 STAINLESS KEPT NUT	4
2	376182	STRIKER PIN MOUNTING PLATE	1
	54659	STRIKER PIN	1
	81115	STAINLESS CARRIAGE BOLT 5/16-18 x 3/4	2
	82110	FLAT WASHER 5/16	4
	82130	LOCK WASHER 5/16	2
	83110	NUT 5/16-18	2
	83125	NYLON LOCK NUT 5/16-18	1
3	379100W	BOX WELDMENT	1
4	37741	DOOR WELDMENT	1
	37740	DOOR ASSEMBLY	1
5	81100	STAINLESS CARRIAGE BOLT 1/4-20 x 3/4	6
	83105	NYLON LOCK NUT 1/4-20	6
	37744	DOOR REINFORCEMENT	1
6	37735	HINGE	1
	811014	SS SOCKET BUTTON HEAD BOLT 1/4-20 x 7/8	2
	811012	SS SOCKET BUTTON HEAD BOLT 1/4-20 x 3/4	3
	811010	SS SOCKET BUTTON HEAD BOLT 1/4-20 x 5/8	5
	83105	NYLON LOCK NUT 1/4-20	10
7	37760	TANDEM BOX SPACER CHANNEL (OPTIONAL)	1
8	37855L	TANK AND TOOLBOX MOUNTING BRACKET-LEFT	1
9	37855R	TANK AND TOOLBOX MOUNTING BRACKET-RIGHT	1
10	5A221	LANYARD-21 INCH	2
11	37770	SHELF	1

Section V - PARTS

PINTLE HITCH GROUP

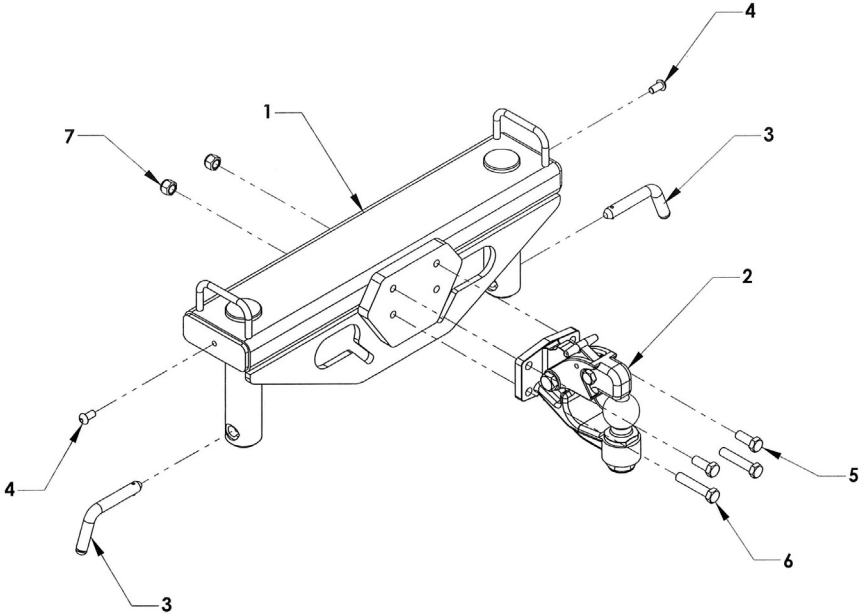

REF	PART #	DESCRIPTION	QPU
	66370G	PINTLE HITCH GROUP	1
1	66370W	PINTLE HITCH WELDMENT	1
2	A3020	TOW BALL PINTLE HITCH	1
3	66378	RETAINING PIN	2
4	812A6	3/8 X 5/8 BUTTON HEAD BOLT	4
	5A220	LANYARD	2
5	81428	BOLT 1/2-13 X 1.25 GRADE 8 SECURE WITH LOCTITE	2
6	81449	BOLT 1/2-13 X 2.5 GRADE 8	2
7	83312	NUT NYLOK 1/2-13	2

Section V - PARTS RETRACTABLE LADDER

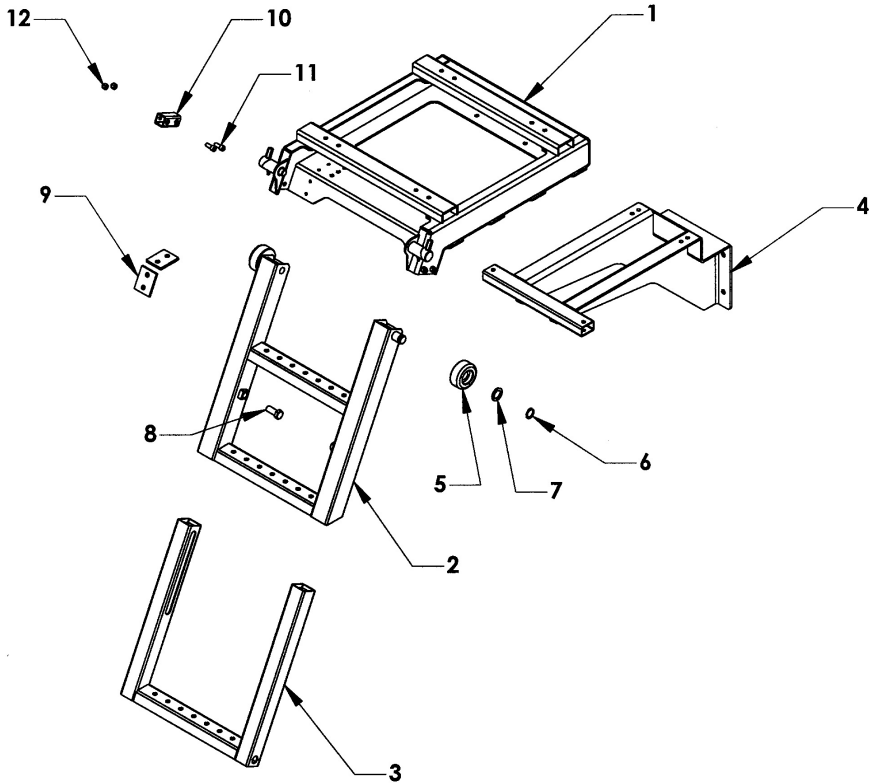

REF	PART #	DESCRIPTION	QPU
	390000	LADDER ASSEMBLY	1
1	391010	LADDER CARRIAGE	1
2	391020	UPPER RUNG ASSEMBLY	1
3	391030	LOWER RUNG ASSEMBLY	1
4	391040	FRAME MOUNTING BRACKET-OPTIONAL	1
5	36310	WHEEL	2
6	86100E	RETAINING RING 1.00 EXTERNAL	2
7	82710	FLAT WASHER 1 x 1.50	2
8	391026	RETAINING BOLT 5/8-11 x 1-1/2	2
9	391018	WEAR PAD	4
10	391015	RETAINING TUBE	2
11	81221	ALLEN HEAD BOLT 3/8-16 x 1	4
12	83211	NYLON LOCK NUT 3/8-16	4

Section V - PARTS CAB CARRIER COMPONENTS

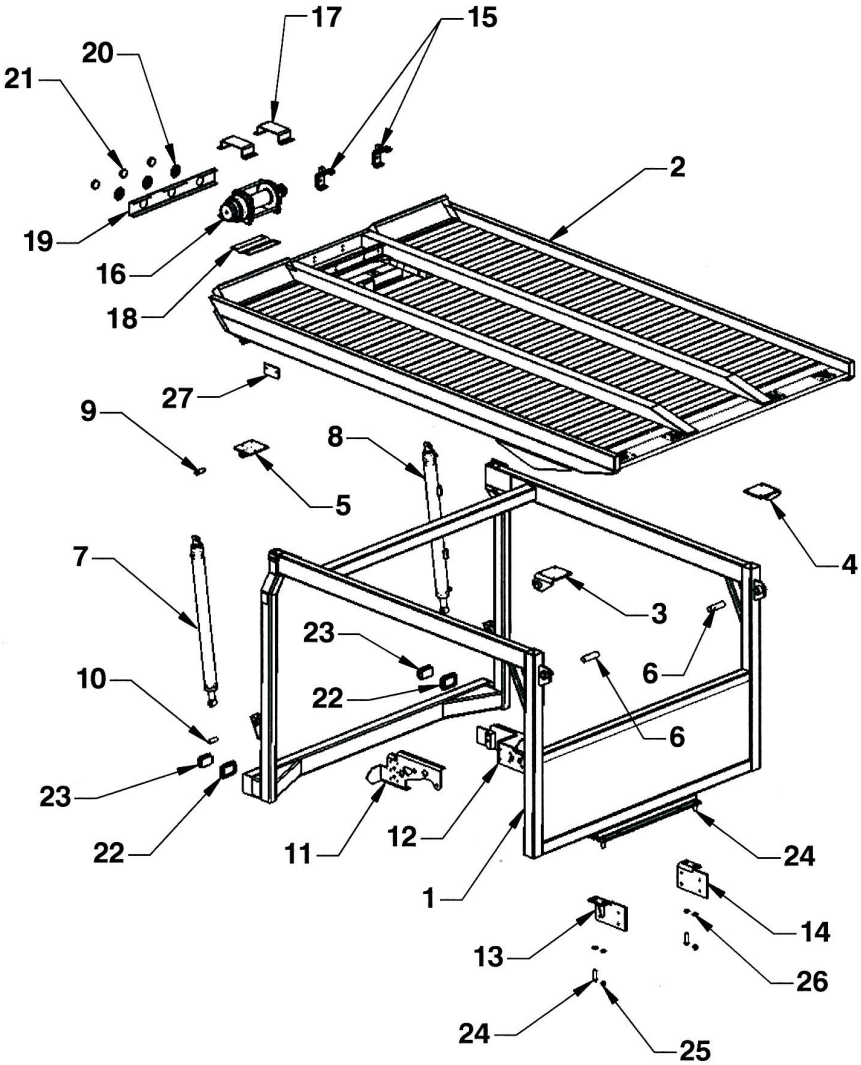

Section V - PARTS CAB CARRIER COMPONENTS

REF	PART #	DESCRIPTION	QPU
1	40104	FRAME-GM KODIAK, INTERNATIONAL 4900	1
	40105	FRAME-INTERNATIONAL 4400, KENWORTH FREIGHTLINER FL70	1
	40106	FRAME-FORD F750	1
2	41800	STEEL DECK-STANDARD	1
	41801	STEEL DECK-SETBACK	1
	41854	ALUMINUM DECK-STANDARD	1
	41855	ALUMINUM DECK-SETBACK	1
3	45165L	HINGE PLATE-LEFT	1
4	45165R	HINGE PLATE-RIGHT	1
5	451400	CYLINDER BRACKET	2
6	45120	HINGE PIN	2
7	72130L	LIFT CYLINDER-LEFT	1
8	72130R	LIFT CYLINDER-RIGHT	1
9	451404	CYLINDER PIN-TOP	2
10	43140	CYLINDER PIN-BOTTOM	2
11	4343101L	INT'L/FORD FRONT MOUNTING BRACKET-LEFT	1
	434300M2L	FREIGHTLINER M2 FRONT MTG BRACKET-LEFT	1
	434305KWL	KENWORTH FRONT MOUNTING BRACKET-LEFT	1
12	4343101R	INT'L/FORD FRONT MTG BRACKET-RIGHT	1
	434300M2R	FREIGHTLINER M2 FRONT MTG BRKT-RIGHT	1
	434305KWR	KENWORTH FRONT MOUNTING BRACKET-RIGHT	1
13	43250L	REAR MOUNTING BRACKET-LEFT GENERIC	1
	43250L2	REAR MGT BRKT-LEFT LARGE INT'L FUEL TANK	1
	43250M2L	REAR MOUNTING BRACKET-LEFT M2	1
14	43250R	REAR MOUNTING BRACKET-RIGHT GENERIC	1
	43250M2R	REAR MOUNTING BRACKET-RIGHT M2	1
15	43535	SAFETY CHAIN HOOK	2
16	71102	PLANETARY WINCH	1
	87141	WINCH CABLE 3/8 x 62 FT.	1
17	41817	CAB CARRIER WINCH COVER - WARN	2
18	41819	DRUM SUPPORT MOUNTING PLATE	1
19	43510	ALUMINUM BEZEL	1
20	93150	GROMMET-MARKER LIGHT	3
21	93100A	MARKER LIGHT-AMBER	3
22	96550	GROMMET-TURN SIGNAL	2
23	98010	TURN SIGNAL-AMBER	2
24	81610	BOLT 3/4-10 UNC x 3 GRADE 5	4
25	83520	NYLON LOCK NUT 3/4-10 UNC	4
26	82510	FLAT WASHER 3/4	8
27	12332C	WEAR PAD	2

Section V - PARTS STABILIZER COMPONENTS

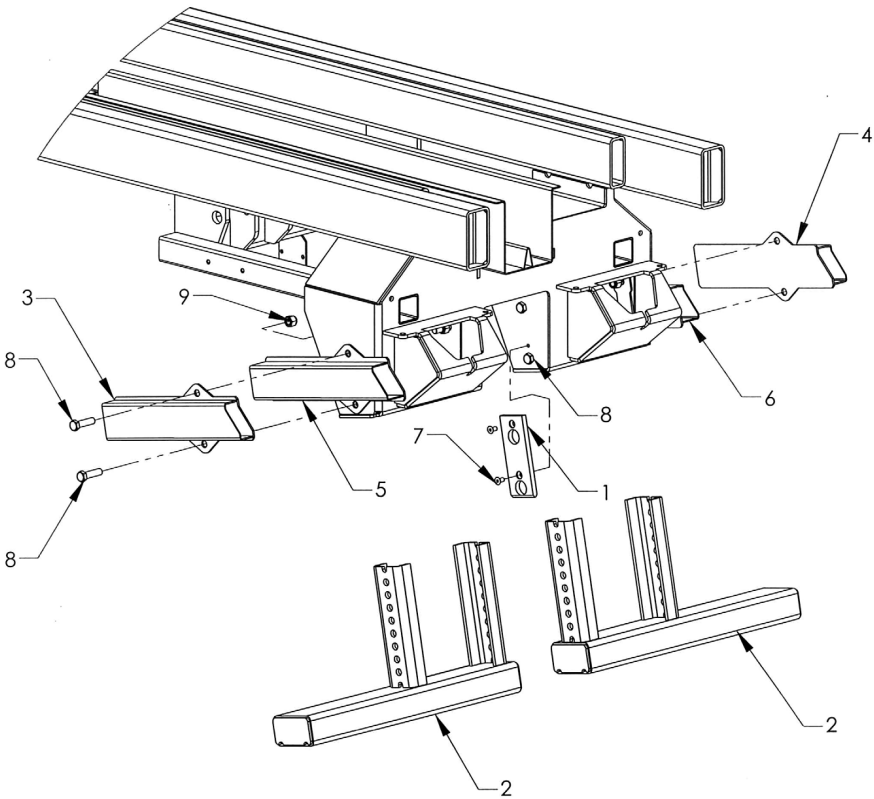

REF	PART #	DESCRIPTION	QPU
1	160519	STABILIZER WHEEL LIFT GUIDE PAD	2
2	160520	STABILIZER EXTENSION STAND	2
	160525	STABILIZER EXTENSION STAND - LOW PROFILE	2
3	160535L	STEEL L-ARM STABILIZER STORAGE TUBE - LEFT	1
4	160536R	STEEL L-ARM STABILIZER STORAGE TUBE - RIGHT	1
5	160530L	ALUMINUM L-ARM STORAGE TUBE - LEFT (OPTIONAL)	1
6	160530R	ALUMINUM L-ARM STORAGE TUBE - RIGHT (OPTIONAL)	1
7	81412	BOLT 3/8-16 UNC x 3/4 FLAT SOCKET HEAD COUNTERSUNK	4
8	81522	BOLT 5/8-11 UNC x 2-1/4	8
9	83411	NUT 5/8-11 UNC NYLON LOCK	8